



# GOURMET

## The flexible consumption counter

The No.1 for individual  
success concepts.

From vision to realisation.  
From counter to large-scale project.

**AICHINGER**

Shops for Success.

## GOURMET

# FLEXIBLE. ERGONOMIC. HYGIENIC.

Ergonomics, functionality and comfort provide optimal profitability and efficiency.

GOURMET is one-hundred percent adaptable to your business and gastronomic concept, your desires and requirements. The flexible design pattern makes any form, size and equipment possible – GOURMET is universally applicable.

Your staff's work load will be noticeably lightened, enabling them to concentrate completely on sales. You benefit from maximum motivation, reliable hygiene and efficient technology.

And, of course, GOURMET is fully compatible and combines perfectly with all other AICHINGER counter types.



HYGIENE AND TECHNOLOGY

INVESTMENT SECURITY

## GOURMET

# EXCLUSIVE. ELEGANT. INVITING.

With the GOURMET consumption counter you will stimulate appetites and the desire to purchase – an irresistible customer magnet.

GOURMET is the perfect stage for the appetizing and sales-promoting presentation of your specialties – and moreover flexible in terms of time since the food being offered can be adjusted individually to target groups and customer frequency. Your customers' mouths will be made to water at any time of day. And your cash registers will ring.



PRODUCT PRESENTATION



FRONT-COOKING

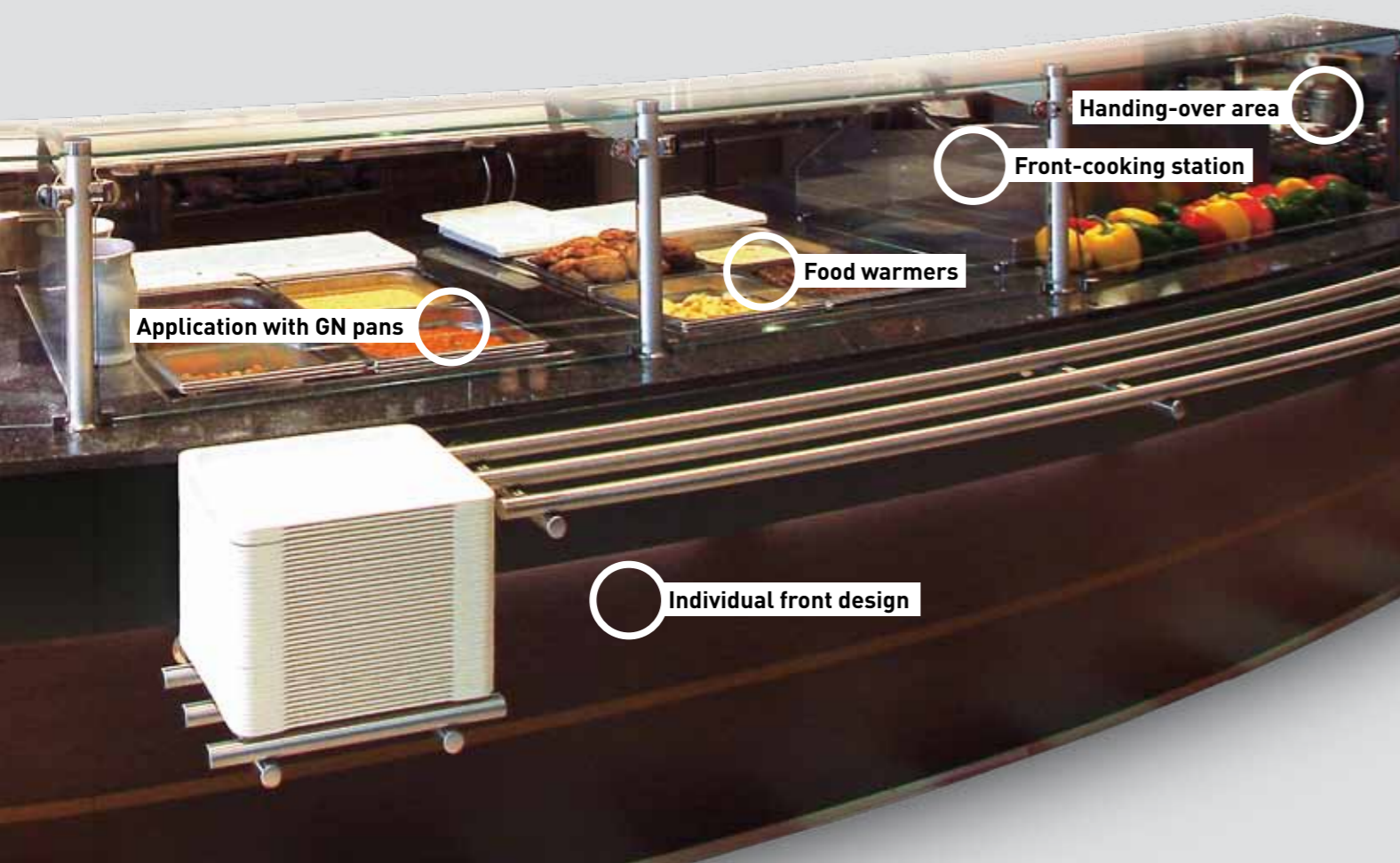

Application with GN pans

Food warmers

Front-cooking station

Handing-over area

Individual front design

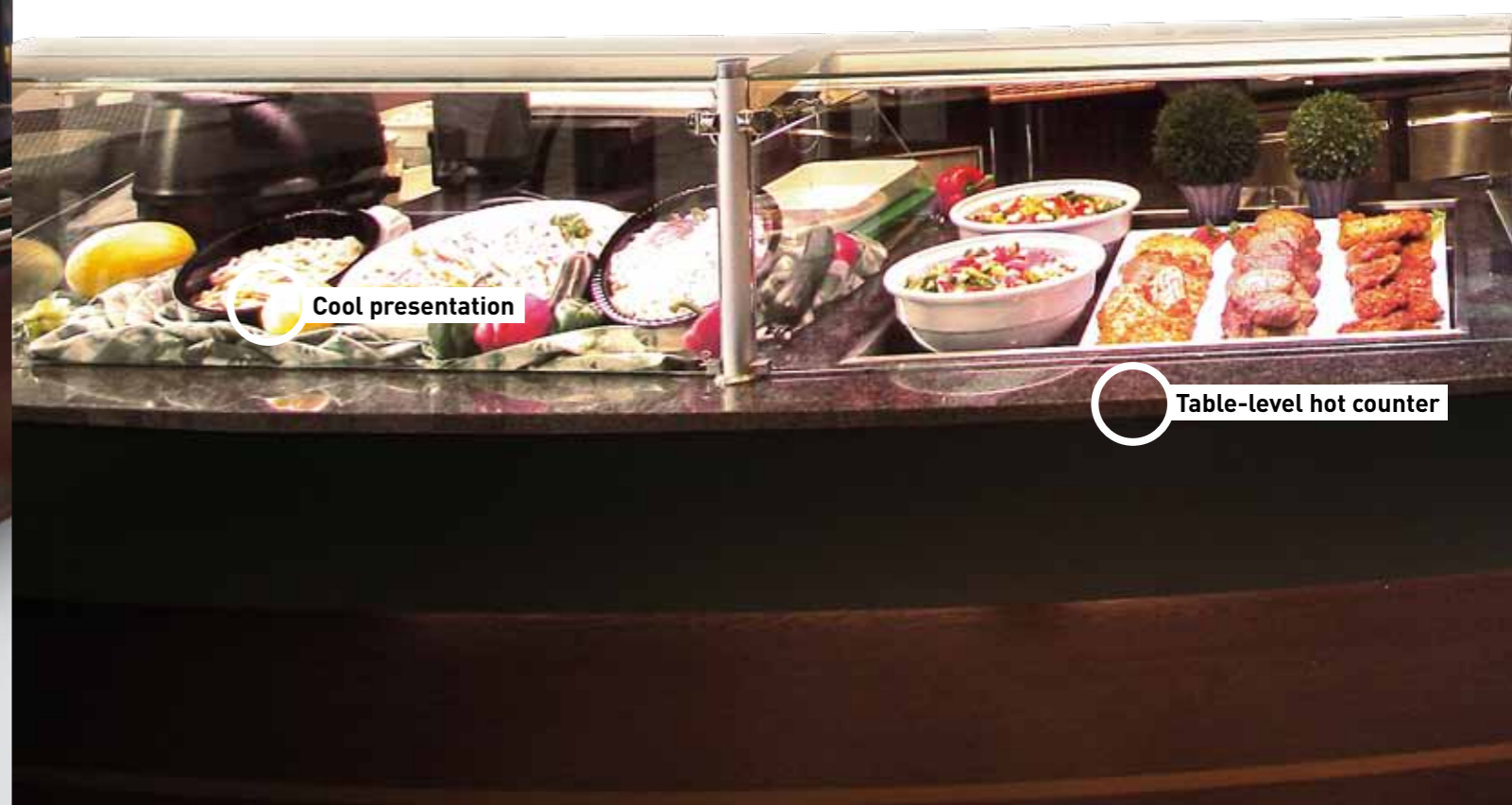

Cool presentation

Table-level hot counter

# PRODUCT PRESENTATION HOT & COLD

In order that your customers' mouths will water at any time of day.

## DESIGN

Working surfaces and counter fronts can be individually designed – also, of course, with the appropriate lighting.



## INSERTS

Various inserts provide the optimal product presentation of your specialties. Whether in GN pans or soup pots – in GOURMET, cold and hot meals are taken care of perfectly.



## GLASS TOPS

The glass tops are standard equipped with angular or curved supports made of stainless steel or aluminum. Upon request GOURMET is also available with the completely support-free ARTline-glass top.



# PREPARATION FRONT COOKING

Always fresh on the table.

## FRONT-COOKING

Preparation right before the customer's watchful eyes demonstrates freshness and quality and stimulates customer frequency. GOURMET is perfectly set up for this.



## COMBINATIONS

No matter what the food or how you want to prepare it – GOURMET provides you with the complete freedom to cook and present as you wish. Whether wok station, pasta cooker, grill or ceramic stovetop – you are in control.



## INDIVIDUALITY

You have a choice of high-class built-in appliances. GOURMET will be customized to suit your requirements – so that you can prepare your customers' food just the way they like it.



# HYGIENE AND TECHNOLOGY

With GOURMET the topic of hygiene is extremely simple.

## INTELLIGENT CONSTRUCTION

- Flush installation of cooking and grill appliances without gaps
- Moulded bain-marie with rounded corners and externally located surface heater
- Minimal gap width between glass, supports and counter top

## INNOVATIVE TECHNOLOGY

- Fully automatic water-level regulation of the bain-marie
- Microprocessor-controlled cooling with freely selectable temperature ranges
- Multifunction-display with documentation and maintenance messages
- Generously designed evaporator for high humidity

## WIDE RANGE OF ACCESSORIES

- Detachable cutting board with integrated juice-collecting pan
- Individual outfitting of the rear area with additional appliances such as combi-steamers, microwave ovens, deep fryers, coffee machines



## MAXIMUM FLEXIBILITY WITH THE HTB BASIN

Varying offers (e. g. stews, casseroles, etc.) can be presented specific to the products with the different inserts in the HTB basin:



High presentation    Soup-In insert    Use of GN pans

The HTB basin functions without a water connection. Food is thoroughly warmed by the rising curtain of heat.

## ADVANTAGES FOR YOU:

- Easy cleaning
- No water installation necessary
- Very good product presentation

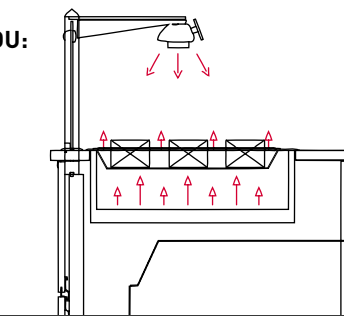

# INVESTMENT SECURITY

Profit from sustainable investment security.

## LOWER OPERATING COSTS

- Conversion of counter from full-service to self-serve is accomplished in seconds
- Reduction in energy demand through electronic ballasts
- Long service life through processing of high-quality materials
- Perfect coordination of all components

## LESS LOSS DUE TO SPOILAGE

- More careful storage through perfect storage conditions
- Separately controlled upper heat and lighting
- Distinctly improved hygiene through optimized antibacterial protection

## OPTIMAL ERGONOMICS FOR MORE ENJOYMENT OF WORK

- Ergonomic working environment for low level of physical strain
- Safe cable routing by integrated electrical and EDP cable duct

## PATENTED GLASS TOP WITH UNIQUE DOUBLE FUNCTION:

- By simply raising the front panel the counter can be converted from full-service to self-serve.
- The front panel locks itself into the self-serve position automatically and safely.
- Payment shelf can be easily raised and removed.
- Easiest cleaning possible through easy access to all glass panes and components.



Example GOURMET with various product categories:



# AICHINGER. The multi-specialist for your complete custom solution from a single source.

## OUR SERVICES FOR YOU AT A GLANCE:

- Concept consultation
- Design + furnishing planning for sales, consumption, preparation, kitchen
- Lighting design and concept
- Custom production
- Project management and construction coordination
- Turnkey installation
- After-sales service

## SUPPLEMENTARY ADDED-VALUE SERVICES:

For your “completely-carefree-package” we will work together with selected partners – each a specialist in a specific field:

- Location analysis / consultation
- Financing / leasing
- Advertising / marketing
- Seminars for experts / trend travel
- Gastronomic system consultation
- Air quality / odour management



## AICHINGER.

The No.1 for individual success concepts.

From vision to realisation.

From counter to large-scale project.

[www.aichinger.de](http://www.aichinger.de)

## ABOUT AICHINGER

- Approx. 350 employees, turnover approx. € 80 million.
- Over 1,500 individually manufactured furnishings per year.
- Approx. 60 interior designers / architects, more than 40 concept consultants in the field
- Two plants with 26,000 m<sup>2</sup> production space.
- Comprehensive network of planning offices in Germany, Austria and Switzerland.
- Sales partners in Europe, Russia and the Middle East.

**AICHINGER GmbH**  
Headquarter  
Ostring 2  
D-90530 Wendelstein  
Tel.: +49 9129/406-0  
Fax: +49 9129/406-130  
zentrale@aichinger.de  
www.aichinger.de

**AICHINGER GmbH**  
Sales Austria  
Premstätterstr. 41  
A-8054 Graz-Pirka  
Tel.: +43 316/28 45 56  
Fax: +43 316/28 69 65  
info@aichinger-austria.at  
www.aichinger-austria.at

**AICHINGER Schweiz GmbH**  
Dammstr. 19  
CH-6301 Zug  
Tel.: +41 41/723 24 74  
Fax: +41 41/723 24 75  
zentrale@aichinger.ch  
www.aichinger.ch

